

Experimental demonstration of the tomatotopic organization in the Soprano (*Cantatrix sopranica L.*)

Georges Perec
Laboratoire de physiologie
Faculté de médecine Saint-Antoine
Paris, France

Sommaire:

Démonstration expérimentale d'une organisation tomatotopique chez la Cantatrice.

L'auteur étudie les fois que le lancement de la tomate il provoque la *réaction yellante* chez la Chantatrice et démontre que divers plusieurs aires de la cervelle elles étaient impliquées dans la réponse, en particulier, le trajet légumier, les noyaux thalamiques et le figure musicien de l'hémisphère nord.

As observed at the turn of the century by Marks & Spencer (1899), who first named the "yelling reaction" (YR), the striking effects of tomato throwing on Sopranos have been extensively described. Although numerous behavioral (Zeeg & Puss, 1931; Roux & Combaluzier, 1932; Sinon *et al.*, 1948), pathological (Hun & Deu, 1960), comparative (Karybb & Szyla, 1973) and follow-up (Else & Vire, 1974) studies have permitted a valuable description of these typical responses, neuroanatomical, as well as neurophysiological data, are, in spite of their number, surprisingly confusing. In their henceforth late twenties' classical demonstrations, Chou & Lai (1927 a, b, c, 1928 a, b, 1929 a, 1930) have ruled out the hypothesis of a pure facio-facial nociceptive reflex that has been advanced for many years by a number of authors (Mace & Doyne, 1912; Payre & Tairnelle, 1916; Sornette & Billeveyzé, 1925). Since that time, numerous observations have been made that have tried to decipher the tangling puzzle as well as the puzzling tangle of the afferent and/or efferent sides of the YR and led to the rather chaotic involvement of numberless structures and paths: trigeminal (Loewenstein *et al.*, 1930), bitrigeminal (Von Aitick, 1940), quadririgeminal (Van der Deder, 1950), supra-, infra-, and inter-trigeminal (Mason & Ragoun, 1960) afferents have been likely pointed out as well as macular (Zakouski, 1954), saccular (Bortsch, 1955), utricular (Malosol, 1956), ventricular (Tarama, 1957), monocular (Zubrowska, 1958), binocular (Chachlik, 1959-1960), triocular (Strogonoff, 1960), auditive (Balalaika, 1515) and digestive (Alka-Seltzer, 1815) inputs. Spinothalamic (Attou &

Ratathou, 1974), rubrospinal (Maotz & Toung, 1973), nigro-suiatal (Szentagothai, 1972), reticular (Pompeiano *et al.*, 1971), hypothalamic (Hubel & Wiesel, 1970), mesolimbic (Kuffler, 1969) and cerebellar (High & Low, 1968) pathways have been vainly searched out for a tentative explanation of the YR organization and almost every part of the somesthetic (Pericoloso & Sporgersi, 1973), motor (Ford, 1930), commissural (Gordon & Bogen, 1974) and associative (Einstein *et al.*, 1974) cortices have been found responsible for the progressive building-up of the response although, up-to-now, no decisive demonstration of both the input and output of the YR programming has been convincingly advanced.

Recent observations by Unsofort & Tchetera pointing out that "*the more you throw tomatoes on Sopranos, the more they yell*" and comparative studies dealing with the gasp-reaction (Otis & Pifre, 1964), hiccup (Carpentier & Fialip, 1964), cat purring (Remmers & Gautier, 1972), HM reflex (Vincent *et al.*, 1976), ventriloquy (McCulloch *et al.*, 1964), shriek, scream, shrill and other hysterical reactions (Sturm & Drang, 1973) provoked by tomato as well as cabbages, apples, cream tarts, shoes, butts and anvil throwing (Harvar & Mercy, 1973) have led to the steady assumption of a positive feedback organization of the YR based upon a semilinear quadristable multi-switching interdigitation of neuronal sub-networks functioning en desordre (Beulott *et al.*, 1974). Although this hypothesis seems rather seductive, it lacks anatomical and physiological foundations and we therefore decide to explore systematically the internal incremental or decremental organization of the YR, allowing a tentative anatomic model.

MATERIALS AND METHODS

Preparation

Experiments were carried out on 107 female healthy Sopranos (*Cantatrix sopranica L.*) furnished by the Conservatoire national de Musique, and weighing 94-124 kg (mean weight: 101 kg). Halothane anesthesia was utilized during the course of tracheotomy, fixation in the Horsley-Clarke, and major operative procedures. 5 % procaine was injected into skin margins and pressure points. Animals were then immobilized with gallamine triethiodide (40 mg/kg/hr) and normocapnia was maintained by appropriate artificial ventilation. Spinal cord transections were performed at L³/T² levels, thus eliminating blood pressure variations and adrenaline secretion induced by tomato throwing (Giscard d'Estaing, 1974). The fact that the animals were not suffering from pain was shown by their constant smiling throughout the experiments. Internal temperature was maintained at 38 °C ± 4 °F by means of three electrically driven boiling kettles.

Stimulation

Tomatoes (*Tomato rurgisia vulgaris*) were thrown by an automatic tomatothrower (Wait & See, 1972) monitored by an all-purpose laboratory

computer (DID/92/85/P/331) operated on-line. Repetitive throwing allowed up to 9 projections per sec, thus mimicking the physiological conditions encountered by Sopranos and other Singers on stage (Tebaldi, 1953). Care was taken to avoid missed projections on upper and/or lower limbs, trunk & buttocks. Only tomatoes affecting faces and necks were taken into account.

Control experiments were made with other projectiles, as apple cores, cabbage runts, hats, roses, pumpkins, bullets, and ketchup (Heinz, 1952).

Recording

Unit activity was recorded through glasstungsten semi-macroelectrodes located *au-petit-bonheur*, according to the methods of Zyszytrakyczywsz-Sekrâwszkiwcz (1974). Spike recognition was performed by audiomonitoring: every time a unit discharge was heard, it was carefully photographed, tapped, displayed on a monograph and, after integration, on a polygraph. Statistical evaluation of the results was made using a tennis like algorithm (Wimbledon, 1974), that is, every time a structure responds up to win the game, it was recognized as YR-related.

Histology

At the end of the experiments, Sopranos were perfused with olive oil, and 10 % GlennFiddish, and incubated at 421 °C in 15 % orange juice during 47 hours. Frozen 2 cm unstained sections were mounted into delta-strawberry sherbet and observed under light and heavy microscopy. Histological verifications confirmed that all the electrodes were located in the brain except four that were found in cauda equina and filum terminale and disclosed from statistical analysis.

RESULTS

Stereotaxic explorations of brains during tomato throwing showed that most of the areas respond differently to the tomesthetic stimulation. As can be seen from [table one](#), where the results are summarized, three (3) distinct areas gave definite, unambiguous and constant responses: the nucleus anterior reticularis thalami pars lateralis (NARTpl), or nucleus of Pesch (Pesch, 1876; Poissy, 1880; Jeanpace & Desmeyeurs, 1932), the anterior portion of the tractus leguminosus (apTL), lying 3.5 mm above the obex and 4 mm right of the tentorium and the dorsal part of the so-called "musical sulcus" (scMS) of the left hemisphere (Donen & Kelly, 1956). It is of interest to notice that, if the left hemisphere was kept for analysis, the right hemisphere was left.

Regions	Tomatic stimulation					
	1/s	2/s	3/s	4/s	5/s	15/s
whole brain	0.0	0.0	4.2	0.6	0.7	000.1
raphe area	3.1	4.1	5.9	5.9	5.9	000.2
septum	±1	67	875	121	000	π3517
thalamus	2.2	√3	456	±7	8.9	0.0001
NARTpl	456	+2	-4	55	* 2 *	±0.001
hypothalamus	±"3	1&2	41	S.G	121	many
hippocampus	1/2	3 %	√J7	?	<16	0, ± ± 7
cereb.cortex	yes	<55	nsp	{0}	±∞	71 ± 70
scMS	~31	~65	>87	00+	345 4	a few
apTL	0.0	3.1	6.7	√4	—	56 %
amygdala	+3	±3	3.3	333	3	√3.33
N. Poissy	→8	0.0	→1	12←	M/5	1+1=2
N.Pesch.	354	781	↑2	↓34	!	!!!!
N:ruber	Λ51	???	∑ ₄ ³	∫ ₀ ⁷	415	maybe

TABLE ONE. Differential responding of tomatic stimulation in the brain at different frequencies.

Examples of responses obtained from these structures can be seen on figure 1 where temporal analysis of the spike distribution based on their Responsive-Area-Temporal-Programming (RATP) properties allowed to distinguish 3 unit subtypes: 1) units responding before the stimulation; 2) units responding during the stimulation and 3) units responding after the stimulation.



Fig. 1: Unit activity in structures responding to tomatic stimulation. Bar indicates stimulus onset & cessation. Calibration: 3.1416 ms. Each trace is made of the superimposition of 33.57 successive recordings. Note the point in A, the arrow in B and the black triangle in C.

Cross-examination of responses driven by other projectiles and Ketchup stimulation are shown on [figure 2](#) and argue unquestionably in favor of a tomatotopic organization of the YR along, between and across the NARTpl, apTL and scMS. Temporal relationships of those responses, as exemplified in [fig. 3](#), showed that the hypothesis of a clustering interdigitation of neuronal subnets is highly probable, although no experimental evidence can be given due to the relative difficulty of entering those damned structures without destroying a lot of things (Timeo *et al.*, 1971).

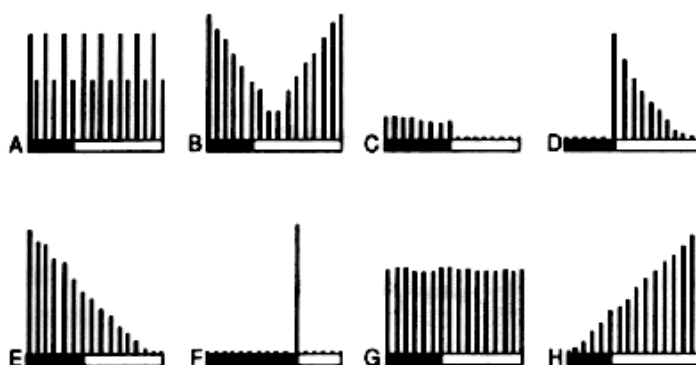

Fig. 2: Examples of response in the apTL provoked by tomato and other throwings. Explanations in text.

A = tomato; B = apple; C = cabbage; D = hats; E = roses;
 F = ketchup (kindly provided by Laroche-Ciba, Inc.); G = pumpkin; H = bullet.

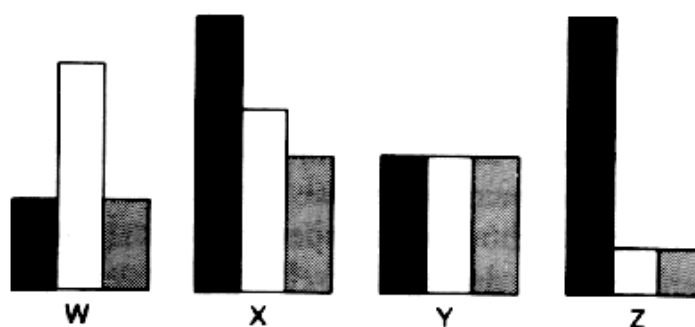

Fig. 3: Temporal relationship of the responses recorded in the YR area. Abscissae: arbitrary units; ordinates: international units. Explanations in text.

DISCUSSION

It has been shown above that tomato throwing provokes, along with a few other motor, visual, vegetative and behavioral reactions, neuronal responses in 3 distinctive brain areas: the nucleus anterior reticular thalami, pars

lateralis (NARTpl), the anterior portion of the tractus leguminosus (apTL) and the dorsal part of the so-called musical sulcus (scMS). As pointed out by Chou & Lai (1929 b), Lai & Chou (1931 a, b) and Unsofort & Tchetera (1972), the YR organization cannot be simply reduced to an oligosynaptic facio-facial nociceptive reflex which would have relayed over in the fascia leguminosa of the VIth laminations of the ventral quadrants of the paleospino-rubro-yello-tectocerebellonigrostriatal tomatonegic ascending pathways. For the fact that horseradish peroxidase injected into the Sopranoes' vocal cords is retrogradually transported from the apical dendrites of the vagus nerves to the tomatotomatic synapses of the contralateral pseudogasserian afferents (McHulott *et al.*, 1975) proves with some likelihood the leguminous nature of the mediator responsible for the transmission of the message from the receptive tomato fields to the YR circuitry (Colle *et al.*, 1973). Thus, 3,5 (M-tri) argyri-beta-L-tomatase which is selectively trisynthetized in the NARTpl-apTL bundle and whose destruction blocks up drastically the YR (Others *et al.*, 1974) stands out as the major candidate for the transmitter involved in the YR retroacting loop, although an alternate hypothesis based upon latency calculations, and cocross frequency correlations, puts forward the feasibility of a tomatotonic synapse (see Dendritt & Haxon, 1975). Although decisive experimental evidences are still lacking and further series of experiment are needed before the complete elucidation of the YR can be achieved, it seems logical to advance that above combined arguments along with experimental results described in our work are likely to support the hypothesis of a semi-linear multi-stable multi-switching net-back feedwork organization of the YR whose a tentative anatomical model can therefore be proposed ([fig. 4](#)).

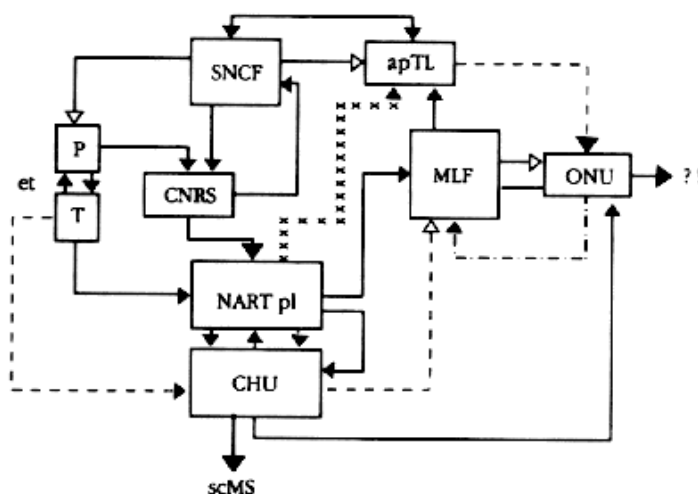

Fig. 4: Tentative anatomical model of the YR organization. Explanations in text or elsewhere.

Black lines = inhibitory; broken lines = interrogatory; dashed lines = redhibitory; stellate lines = whig-and-tory.

This work was supported by grants from the Syndicat régional des Producteurs de Fruits & Légumes, the Association française des Amateurs

d'Art Lyrique (AFAAL) and the Fédération internationale des Dactylo-Bibliographes (FIDB).

The author gratefully acknowledges the helpful criticisms as well as the skilful assistance of J. Chandelier, M. De Miroschedji and H. Gautier.

REFERENCES

- Alka-Seltzer, L. Untersuchungen über die tomatostaltische Reflexe beim Walküre. *Bayreuth Monatschr. f. exp. Biol.* 184, 34-43, 1815.
- Attou, J. & Ratathou, F. Laminar configuration of the thalamo-tomatic relay nuclei. Experimental study with Fink-Heimer-Gygax methods. In: *The Hyperthalamus*, ed. by V. Cointreau and M. Brizard, Cambridge, Oxford U.P., pp. 32-88, 1974.
- Balalaïka, P. Deafness caused by tomato injury. Observations on half a case. *Acta. pathol. marignan.* 1, 1-7, 1515.
- Beulott, A., Rebeloth, B. & Dizdeudayre, C.D. *Brain designing*. Châteauneuf-en-Thymerais, Institute of advanced studies (vol. 17), 1974.
- Bortsch, B. Saccular disturbances produced by whistling (in russian). *Fortschr. Hals-Nasen-Ohrenheilk.* 3, 412-417, 1955.
- Carpentier, H. & Fialip, L. Tomato calibres & swallowing. *Bull. diet. gastrom. Physiol.* 3, 141-167, 1964.
- Chachlik, I. Vocal performance and binoculars. *Covent Gard. J.* 307, 1975-1080, 1959-1960.
- Chou, O. & Lai, A. Tomatic inhibition in the decerebrate baritone. *Proc. koning. Akad. Wiss., Amst.* 279, 33, 1927a.
- Chou, O. & Lai, A. Note on the tomatic inhibition in the singing gorilla. *Acta laryngol.* 8, 41-42, 1927b.
- Chou, O. & Lai, A. Further comments on inhibitory responses to tomato splitting in Soloists. *Z. f. Haendel Wiss.* 17, 75-80, 1927c.
- Chou, O. & Lai, A. Faradic responses to tomatic stimulation in the buzzing ouistiti. *J. amer. metempsych. Soc.* 19, 100-120, 1928a.
- Chou, O. & Lai, A. Charlotte's syndrome is not a withdrawal reflex. A reply to Roux & Combaluzier. *Folia pathol. musicol.* 7, 13-17 1928b.
- Chou, O. & Lai, A. Tomatic excitation and inhibition in awake Counteraltts with discrete or massive brain lesions. *Acta chirurg. concertgebouw., Amst.* 17, 23-30, 1929a.

- Chou, O. & Lai, A. Musicali effetti del tomatino jettatura durante il rappresentazione dell' opere di Verdi. In: *Festschrift am Arturo Toscanini*, herausgegeben vom A. Pick, I. Pick, E. Kohl & E. Gramm., München, Thieme & Becker, pp. 145-172, 1929b.
- Chou, O & Lai, A. Suprasegmental contribution to the yelling reaction. Experiments with stimulation and destruction. *Ztschr. f. d. ges. Neur. u. Psychiat.* 130, 631-677, 1930.
- Colle, E., Etahl, E & Others, S. Leguminase pathways in the brain. A new theory. *J. Neurochem. Neurocytol. Enzymol.* 1, 8-345, 1973.
- Dendritt, A. & Haxon, B. Synaptic contacts in the Lily Pons. *Brain Res.*, 1975 (in the press).
- Donen, S. & Kelly, G. *Singing in the brain*. Los Angeles, M.G.M. Inc. Press. 1956.
- Einstein, Z., Zweistein, D., Dreistein, V., Vierstein, F. & St. Pierre, E. Spatial integration in the temporal cortex. *Res. Proc. neurophysiol Fanatic Soc.* 1, 45-52, 1974.
- Else, K. & Vire, A. de. 45-years tomato throwing on amateur Singers. *New Records Ass. J.* 27, 37-38, 1974.
- Ford, G. Highways and pathways for motor control. *J. pyramid. Soc.* 30, 30, 1930.
- Giscard d'Estaing, V. Discours aux transporteurs routiers de Rungis. *C. r. Soc. fr. Tomatol.* 422, 6, 1974.
- Gorden, H.W. & Bogen, J.E. Hemispheric lateralization of singing after intracarotid sodium amylobarbltone. *J. Neurol. Neurosurg. Psychiat.* 37, 727-738, 1974.
- Harvar, D. & Mercy, B.C.P. Reward and punishment in Olympic throwers. *Hammersmith J.* 134, 12-15, 1973.
- Heinz, D. Biological effects of ketchup splatching. *J. Food Cosmet. Ind.* 72, 42-62, 1952.
- High, A.B.C.D. & Low, E.F.G.H. Cerebellar aphonia and the Callas syndrome. *Brain* 91, 23-1, 1968.
- Hubel, D.H. & Wiesel, T.N. Receptive & tomato fields in the zona incerta. *Experientia* 25, 2, 1970.
- Hun, O. & Deu, I. *Tonic, diatonic, & catatonic stage-distress syndromes*. Basel, Karger, 1960.
- Jeanpace, L. & Desmeyeurs, P. Recherches histologiques sur les noyaux de Pesch & de Poissy. *Dijon med.* 5, 1-73, 1932.

- Karybb, H. & Szyla, H. Of birds and men: calling strategies and humming responses. *Biol. Gaz. Elec.* 73, 19-73, 1973.
- Kuffler, S.W. Papezian control of aggressive borborygms in Julliard drop-out. *J. physiol. Physiol.* 2, 21 -42, 1969.
- Lai, A. & Chou, O. Dix-sept recettes faciles au chou et a l'ail. I. Avec des tomates. *J. Ass. philharmon. Vet. lang. fr.* 3, 1-99, 1931a.
- Lai, A. & Chou, O. Dix-sept recettes faciles au chou et a l'ail. II. Avec d'autres tomates. *J. Ass. philharmon. Vet. lang. fr.* 3, 100-1, 1931b.
- Loewenstein, W.R., Lowenfeld, I., Löwencraft, N., Löwoenshrift, Q. & Leuwen, X. Tomatic neuralgia. *J. Neurosurg. Psychiat. Neurol.* 340, 34-89, 1930.
- Mace, I. & Doyne, J. Sur les différents types de réactions tomateuses chez la Cantatrice. *Gaz. méd. franco-rus.* 6, 6-11, 1912.
- Malosol, T. Utricular responses during tomato conditioning. *Bull. med. Aunis & Saintonge* 43, 6-11, 1956.
- Maotz, E. & Toung, I. Tomatic innervation of the nucleus ruber. *Proc. Opossum Soc.* 70, 717-727, 1973.
- Marks, C.N.R.S. & Spencer, D.G.R.S.T. About the frightening reactions that accompanied first performances of *Il trovatore* at the Metropolitan. *Amer. J. music. Deficiency* 7, 3-6, 1899.
- Mason, H.W. & Rangoun, S.W. Paratrigeminaloid musicalgia. In: *3rd Conference on the Rimsky-Korsakoff syndrome*, ed. by T. Thanos & P. Roxidase, Springfield, Ill., C. C. Thomate, pp. 31-57, 1960.
- McCulloch, W.S., Pitts, W.H. & Levin, R.D.Jr. What's the frog stomach tells to the frog's audience. *Proc. Leap & Frog Ass.* 64, 643-1201, 1964.
- McHulott, E., Mac Haskett, E. & Massinture, .T.C. Fate of exogenous (14C) scotch, (235U) bloodymary and other tritiated compounds injected in laryngeal and pharyngeal pathways. *Clin. Bull. B.P.R. Soc.* 89, 35-78, 1975.
- Others, S., Colle, E. & Etahl, E. The enzymase enigma revisited. *Am. J. Allegrol.* 43, 234-567, 1974.
- Otis, J. & Pifre, K. Gasping in the ascending pathways. In: *Hommage à Henri Eiffel*, ed. by D. Haux & D. Bas, Paris. C.N.R.S., pp. 347-950, 1964.
- Payre, L. & Tairnelle, E. Sur le sursaut tomateux du Baryton léger. *C.R. Assoc. Conc. Lam.* 45, 6-7, 1916.
- Pericoloso, O. & Sporgersi, I. Sull'effetti tomestetiche e corticali della stimolazione di leguminose nella Diva. *Arch. physiol. Schola Cantor.* 37, 1805-1972, 1973.

- Pesch, U. Experimentelle Beitrage uber anterior reticularis Kerne beim Minnesanger. *Von Bulow's Arch. f. d. ges. Musikol. 1*, 1-658, 1876.
- Poissy, N. de. Atrophie congénitale des Noyaux de Pesch. *Bibl. clin. Homeoprat. Lugdun. 65*, 22-31, 1880.
- Pompeiano, O., Vesuviana, A., Strombolino, H. & Lipari, G. Volcaniche effetti della formazione reticolare nella funiculi funicula. *C.r. Ass. ital. Amat. Bel Cant. 37*, 5-32, 1971.
- Remmers, J.E. & Gauthier, H. Neural and mechanical mechanisms of feline purring. *Respir. Physiol. 16*, 351-361, 1972.
- Roux, C.F. & Combaluzier, H.U. Le syndrome de Charlotte. *Weimar Ztschr. musikol. Pomol. 7*, 1-14, 1932.
- Sinon, E., Evero, I & Ben Trovato, A. Psychopathological description of *La Furia di Caruso* (in italian). *Folia clin. oto-rhinolaryngol., Fourn Tataouine 6*, 362-363, 1948. (Quoted by Hun & Deu, 1960).
- Sornette, U. & Billeveyzé, H. Les stomatites tomateuses. *Arch. municip. Météorol. lyr. Déontol. music. 264*, 14-18, 1925.
- Strogonoff, H., III. Pineal activation and the yelling reaction. *Show Busin. med. Gaz. 3*, 273-308, 1960.
- Sturm, U. & Drang, F. *Musikalische Katastrophe*. Berlin, W. de Gruyter, 1973.
- Szentagothai, J. The substantia nigra as a striatal machine. *Bull. Ass. niger. Neurophysiol. clin. exp., Niamey 23*, 25-40, 1972.
- Tarama, K. *Acid-base balance*. pHD Thesis, San Francisco, 1957.
- Tebaldi, R. La Callas revisited. *Metropolitan J. endocrin. Therap. 6*, 37-73, 1953.
- Timeo, W., Danaos, I. & Dona-Ferentes, H.E.W. Brain cutting and cooking. *Arch. metaphys. endogen. Gastrom. 56*, 98-105, 1971.
- Unsofort, H & Tchetera, K.G.B. Shout and Yell. *Yale J. Med. 9*, 9-19, 1973.
- Van der Deder, J. Von. The yelling pathway. *San Diego J. exp. Teratol. 50*, Suppl. 24, 1 -28, 1950.
- Vincent, J., Milâne, J., Danzunpré, J.J. & Sanvaing-Danlhotte, J.J.J. Le réflexe hydro-musical. *Gaz. med. Faidh. Chalign. & d.s. Fil.*, 1976 (in the press).
- Von Aitick, A. Ueber geminal-niebelungenischen Schmerz. *Ztschr. exp. pathol. Tomatol. 4*, 4a-64P, 1940.

Wait, H. & See, C. Ballistic requirements in tomato throwing and splatching. *Nasa Rept. N°68/67S/002/F4*, 1-472, 1972.

Wimbledon, A.F.G.H. On the Statistical matching of neuronal and other data. *J. dynam. Stat.* 5, 1-28, 1974.

Zakouski, B.G.H. Investigations d'avant-garde sur les voies fluviales artificielles à moitié rondes dans le hall d'entrée (traduit du russe). *Exp. J. sechenov. Pflugerol.* 3, 17-34, 1954.

Zeeg, O & Puss, I.K. On the fanatic demonstrations of music lovers. *J. behav. developm. Psychobiol.* 31, 1-13, 1931.

Zubrowska, A. Oculo-tomatic dyskinesia. A preliminary report. *J. neuro-neurol. Neurol.* 1, 107, 1958.

Zyszytrakyczywsz-Sekrâwszkiwcz, I. The Monte Carlo theorem as a use in locating brain and other sites. *J. math. Vivisecc.* 27, 134-143, 1974.

Source de la numérisation :

<http://xavierleroy.org/stuff/tomato/tomato.html>